

# 3-D Manhole Scanning





**R.H. BORDEN**

**AND COMPANY, LLC**

Independent Manufacturer's Representatives,  
Distributors and Consultants

# 3-D Spider Scan Deliverables – Variance Analysis

	Inspection Area	Annual Ma Inspection 	3-D Manho Scanning 
<b>Operation / Risk Management</b>	Good / Fair / Poor Rating for External Structures	✓	✓
	Good / Fair / Poor Rating for Internal Structures	✓	✓
	Identification of missing or unmapped manholes	✓	✓
	Identify active infiltration	✓	✓
<b>Asset / Budget Management</b>	Identify inactive infiltration		✓
	Quantify wall degradation / protrusion within 1mm		✓
	Identify and quantify structural defects within 1mm		✓
	Generate dimensions of all features within 1mm		✓
	Pre-Post rehabilitation analysis		✓

# RH Borden Manhole Inspection and Scanning

---



# Benefits of 3-D Scanning Manholes

- Prioritize Manhole Rehabilitation
- Budget Planning
- Identify Inactive Infiltration
- Monitor Wall Thickness Degradation
- Assess Pre-Post Rehab Activities
- Improved safety for confined spaces

# 3-D Spider Scan Deliverables Dimensional Analysis

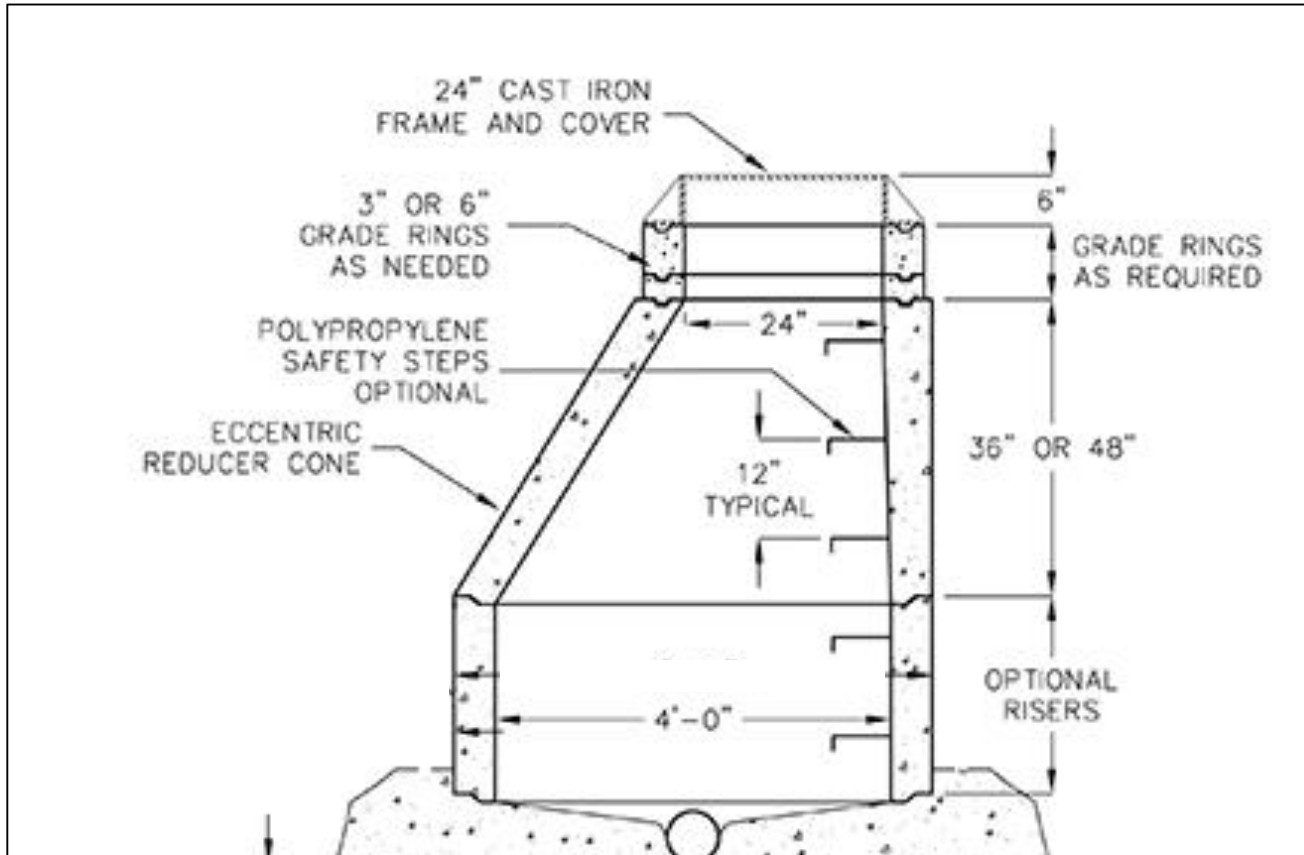

## View Manhole Dimensions

Manhole Invert

Cone Height

Barrel Height / Diameter

Adjoining Pipe Diameter

Pipe Depth

Shelf Levels

# 3-D Spider Scan Deliverables

## Wall Variance Analysis

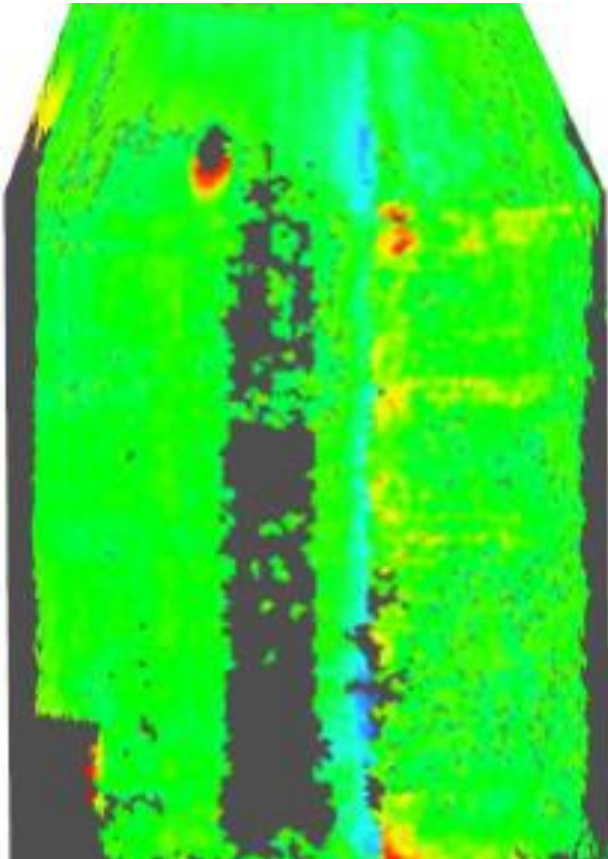

	Variance (in)	Type of Variance	Occurrence%
	3.9-4.7	Loss	0.7%
	3.5-3.9	Loss	0.8%
	2.8-3.5	Loss	1.3%
	2.4-2.8	Loss	2.2%
	1.6-2.4	Loss	3.8%
	0.8-1.6	Loss	8.2%
	0.4-0.8	Loss	24.3%
	0-0.4	No Change	43.1%
	0.4-0.8	Protruding	7.6%
	0.8-1.6	Protruding	4.5%
	1.6-2.4	Protruding	1.5%
	2.4-2.8	Protruding	0.9%
	2.8-3.5	Protruding	0.4%
	3.5-3.9	Protruding	0.3%
	3.9-4.7	Protruding	0.2%

## View Wall Thickness Changes

As Built

Vs.

Current State

---

Pre-Rehab

Vs.

Post-Rehab

---

Today

Vs.

Next Year

# 3-D Spider Scan – Pricing

Video



Point Cloud



Wall Analysis

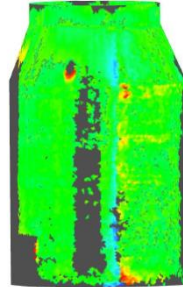

## Interactive Software and Online Access to Manholes

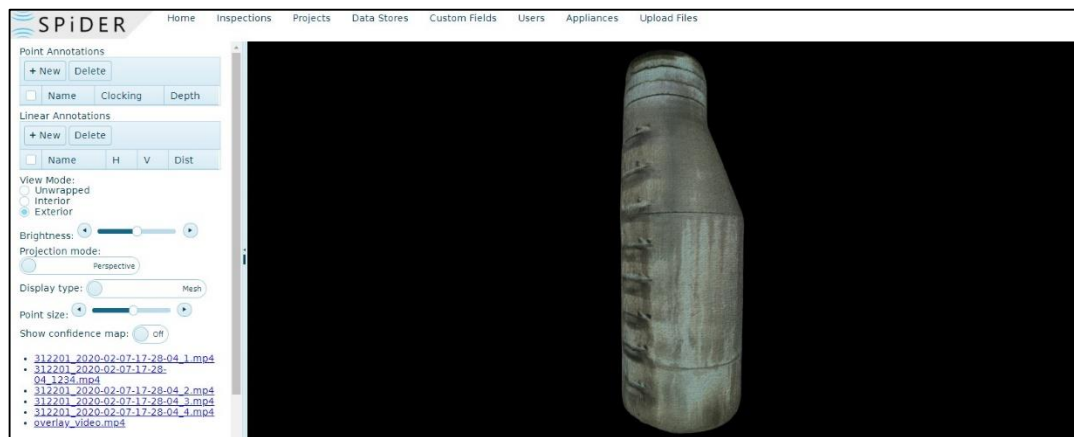

Qty	Price Per Manhole
25	\$400
50	\$300
100	\$250
200-700	\$200
700	\$195
800	\$185
900	\$175
1000	\$165